

## VENTILE REIHE 70, PNEUMATISCH

TECHNISCHE DATEN	1/8"	1/4"	1/2"
Arbeitsdruckbereich	Vakuum bis 10 bar		
Minimaler Arbeitsdruck	2.5 bar		
• monostabil	1 bar		
• bistabil	-10° bis 60°C		
Temperaturbereich	-10° bis 60°C		
Nenndurchmesser	5 mm	7.5 mm	15 mm
Durchflussleistung C [NI/min · bar]	121.43	264.26	971.43
Kritischer Faktor b	0.32 bar/bar	0.27 bar/bar	0.43 bar/bar
Durchfluss bei 6 bar ΔP 0.5 bar	400 NI/min	750 NI/min	3200 NI/min
Durchfluss bei 6 bar ΔP 1 bar	550 NI/min	1100 NI/min	4600 NI/min
TRA/TRR monostabil bei 6 bar	6ms/15ms	7ms/15ms	16ms/46ms
TRA/TRR bistabil bei 6 bar	7ms/7ms	7ms/7ms	16ms/16ms





### TYPENSCHLÜSSEL

P	N	V	2	3	P	N	S	N	C			
FAMILIE			ANSCHLUSS		FUNKTION		BETÄTIGUNG 14		RÜCKSTELLUNG 12		WEITERE DETAILS	
PNV pneumatische Ventile			2 1/8"	3 1/4"	3 3/2	5 5/2	6 5/3	PN pneumatisch		S mechanische Feder	OO 5/2	
										B bistabil	NC normal geschlossen	
										D Differentialkolben	NO normal offen	
										O Mittelstellung 5/3	CC Zentrum geschlossen	
										AA pneumatisch/mechan. Feder*	OC Zentrum entlüftet	
											PC Zentrum belüftet	

## VENTILE REIHE 70, PNEUMATISCH, 1/8"

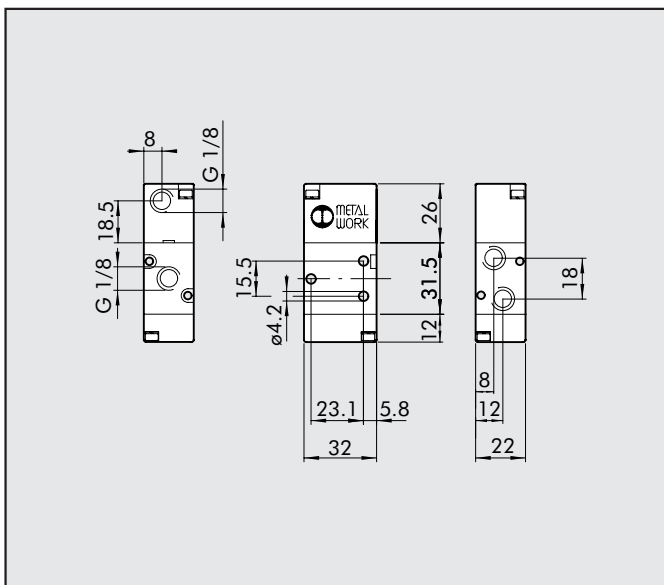
### MONOSTABIL 3/2 NO, 1/8"



Symbol	Typ	Bestellnummer	Gewicht [g]
	PNV 23 PNS NO	7010010400	82

### MONOSTABIL 3/2 NC, 1/8"

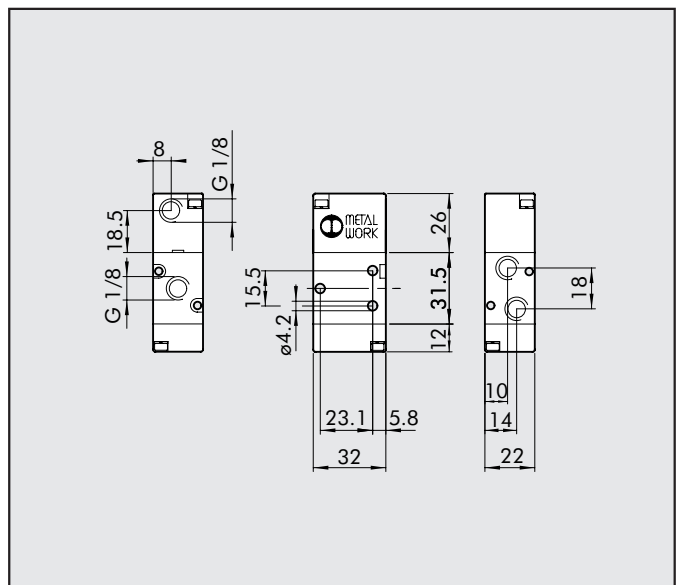

Symbol	Typ	Bestellnummer	Gewicht [g]
	PNV 23 PNS NC	7010010200	82

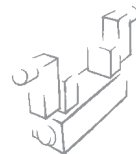

### MONOSTABIL 5/2, 1/8"

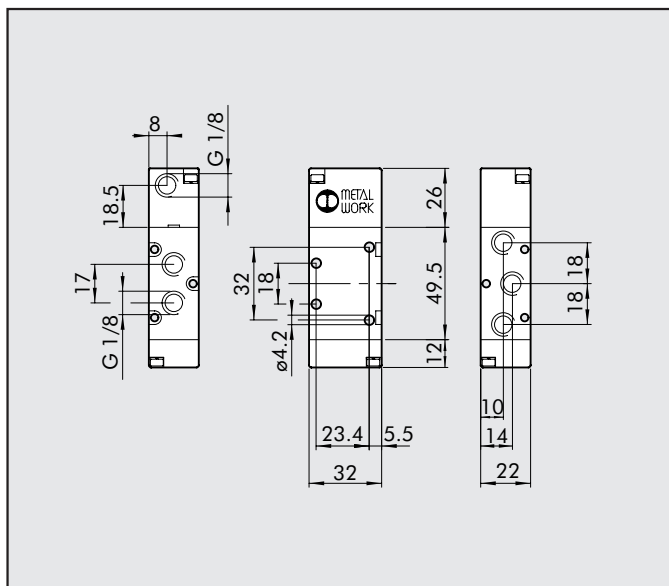

Symbol	Typ	Bestellnummer	Gewicht [g]
→  W	PNV 25 PNS OO	7010011100	108

### BISTABIL 5/2, 1/8"

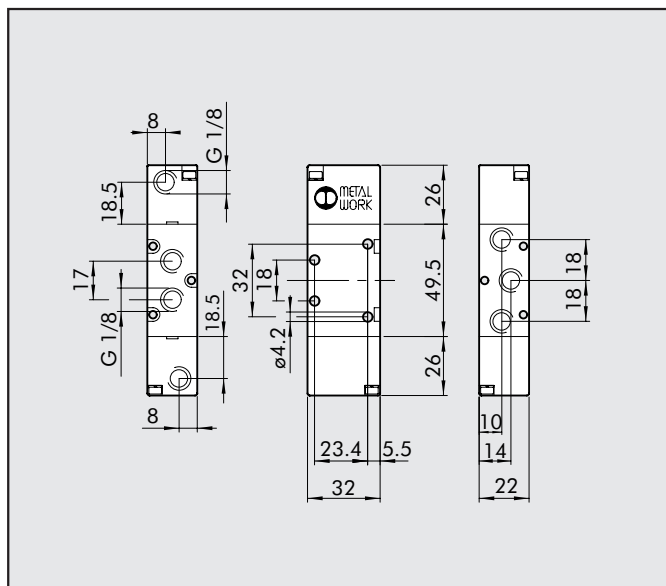

Symbol	Typ	Bestellnummer	Gewicht [g]
→  ←	PNV 25 PNB OO	7010011200	122
→  ←	PNV 25 PND OO	7010011300	128

### BISTABIL 3/2, 1/8"

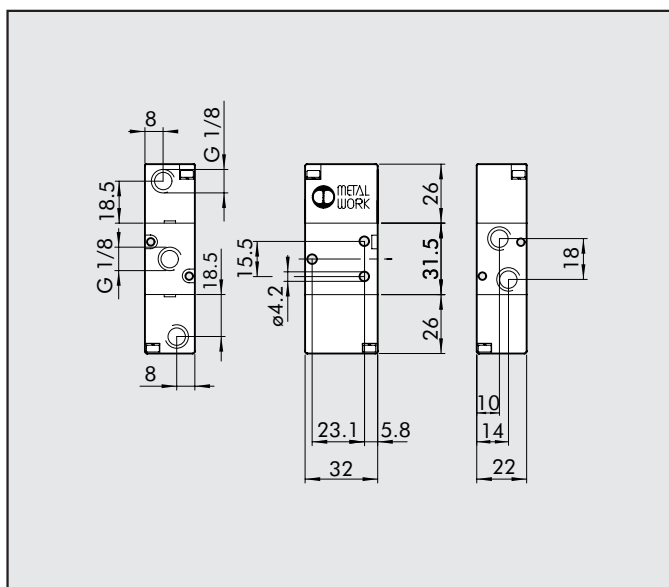

Symbol	Typ	Bestellnummer	Gewicht [g]
→  ←	PNV 23 PNB OO	7010010100	96

### MITTELSTELLUNGS-VENTIL 5/3, 1/8"

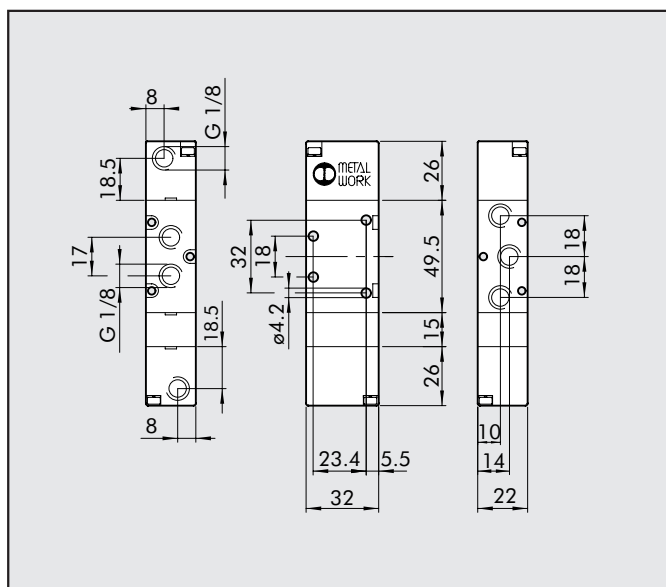

Symbol	Typ	Bestellnummer	Gewicht [g]
→  ←	PNV 26 PNS CC	7010012100	150
→  ←	PNV 26 PNS OC	7010012200	150
→  ←	PNV 26 PNS PC	7010012300	150

## VENTILE REIHE 70, PNEUMATISCH, 1/4"

### MONOSTABIL 3/2 NO, 1/4"

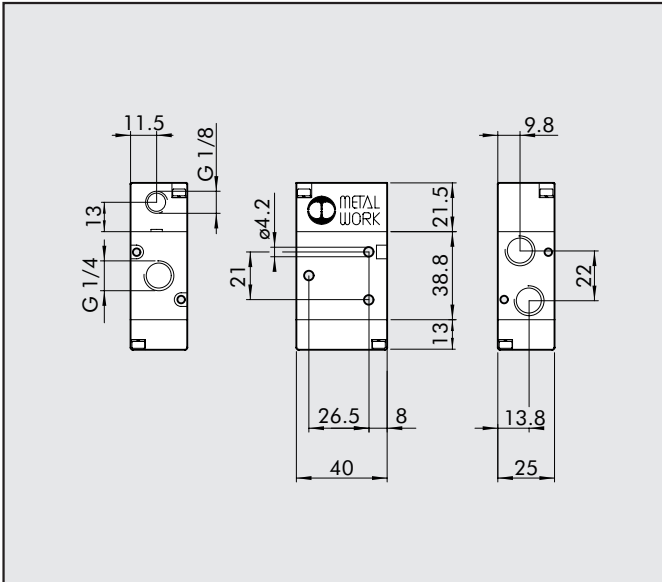

Symbol	Typ	Bestellnummer	Gewicht [g]
→ 	PNV 33 PNS NO	7020010400	124

### MONOSTABIL 3/2 NC, 1/4"

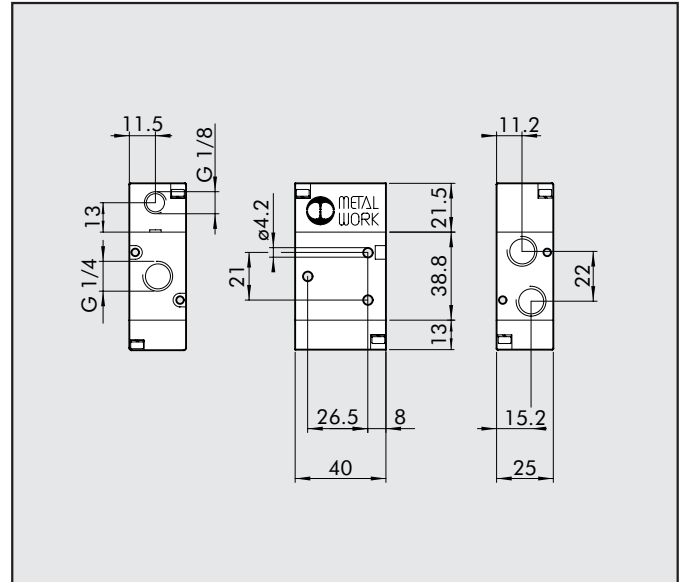

Symbol	Typ	Bestellnummer	Gewicht [g]
→ 	PNV 33 PNS NC	7020010200	122

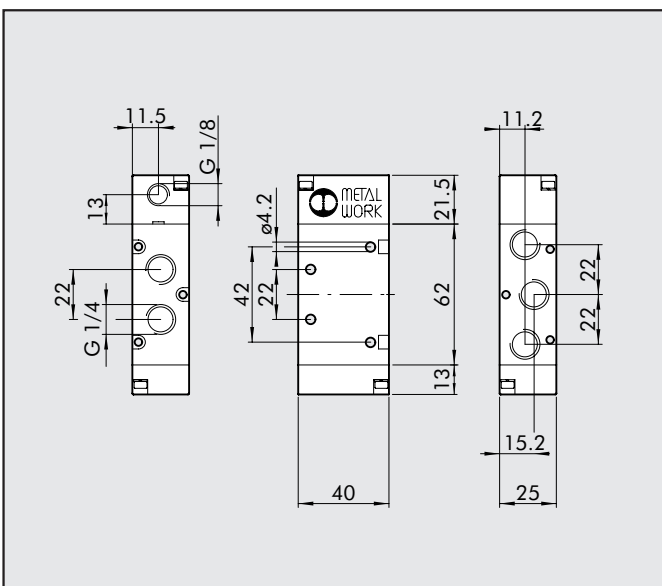

### MONOSTABIL 5/2, 1/4"

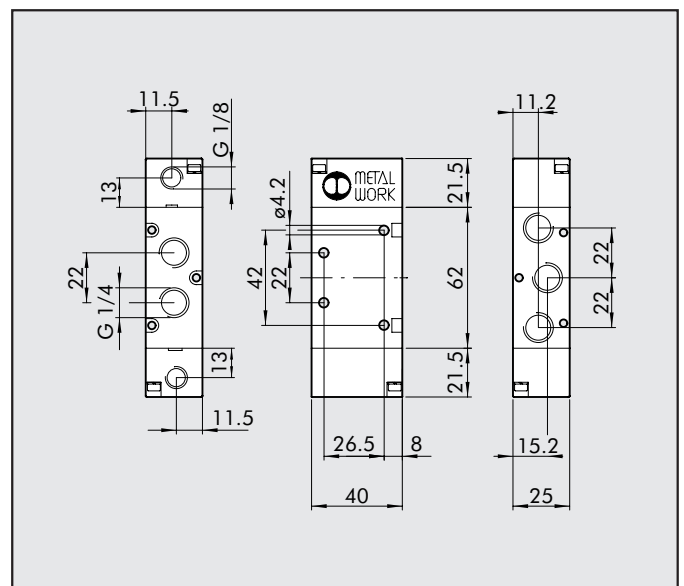

Symbol	Typ	Bestellnummer	Gewicht [g]
→ 	PNV 35 PNS OO	7020011100	174

### BISTABIL 5/2, 1/4"



Symbol	Typ	Bestellnummer	Gewicht [g]
→ 	PNV 35 PNB OO	7020011200	174
→ 	PNV 35 PND OO	7020011300	198



# VENTILE REIHE 70, PNEUMATISCH, 1/2"

## MONOSTABIL 3/2 NO, 1/2"

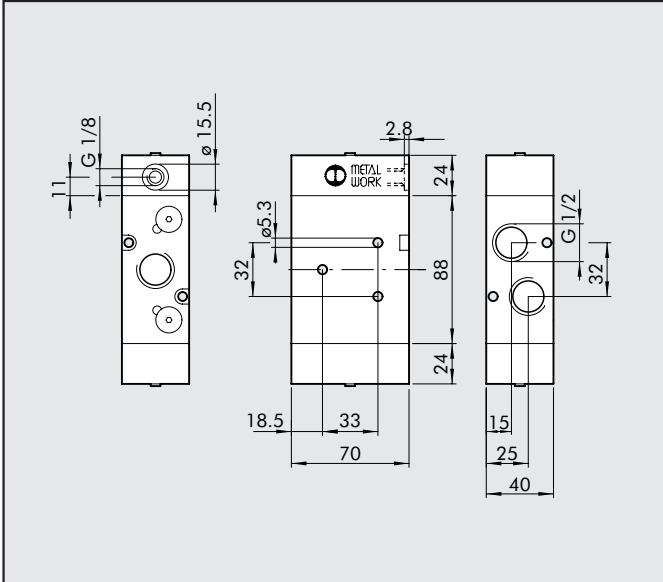

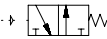
Symbol	Typ	Bestellnummer	Gewicht [g]
	PNV 43 PNS NO	7030010400	905

## MONOSTABIL 3/2 NC, 1/2"

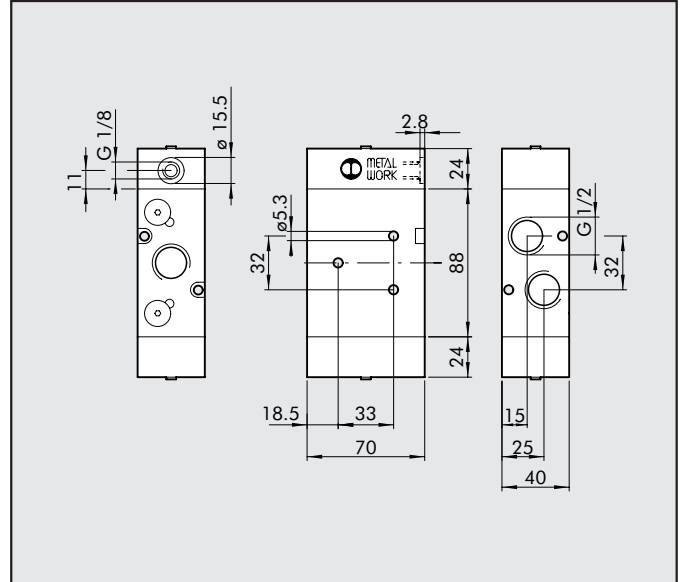

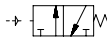
Symbol	Typ	Bestellnummer	Gewicht [g]
	PNV 43 PNS NC	7030010200	905

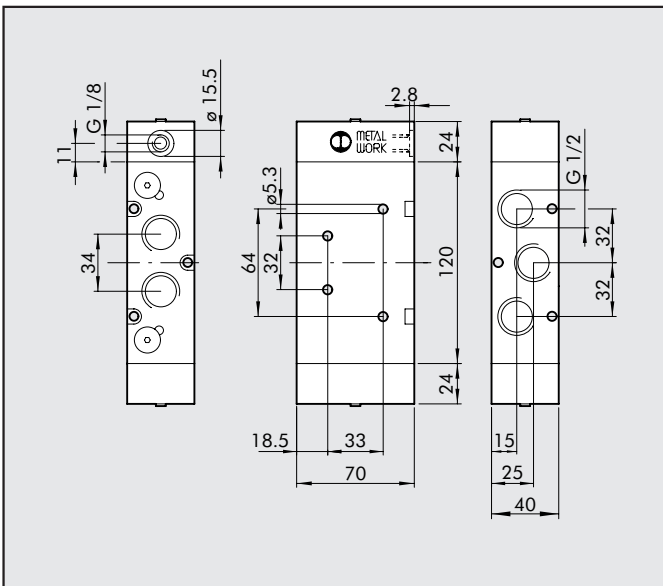

## MONOSTABIL 5/2, 1/2"

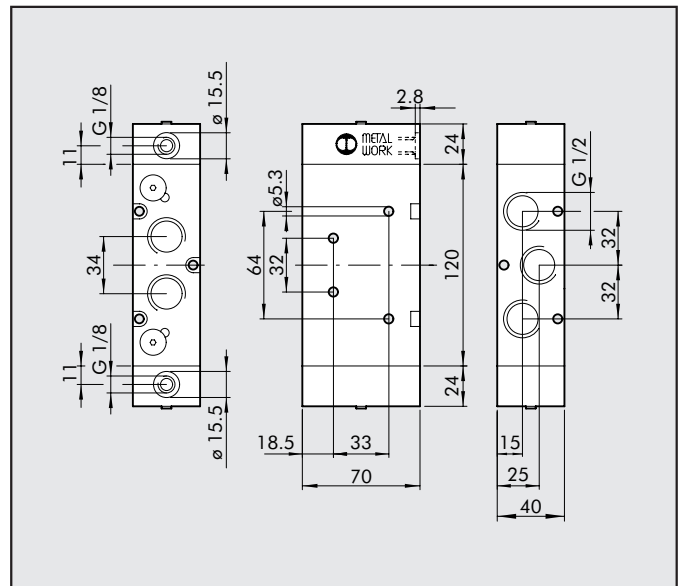

Symbol	Typ	Bestellnummer	Gewicht [g]
	PNV 45 PNS OO	7030011100	1090

## BISTABIL 5/2, 1/2"



Symbol	Typ	Bestellnummer	Gewicht [g]
	PNV 45 PNB OO	7030011200	1077
	PNV 45 PND OO	7030011300	1090

